



BETTER SHIPS, BLUE OCEANS

Digital Twins at MARIN

Jeroen Willemsen



Digitale tweelingen, magische technologie of een illusie?

The background of the slide is a semi-transparent aerial photograph of a coastal area. On the left, there is a large offshore wind farm with numerous white turbines. In the center, a large port facility is visible, featuring several cranes and a long pier extending into the water. Several large cargo ships are docked at the pier. In the foreground, a large container ship is moving through the water, leaving a white wake. Other smaller vessels are scattered throughout the sea.

Our mission is

'Better Ships, Blue Oceans'

We stand for clean, smart and safe shipping and sustainable use of the sea.

Different kinds of models

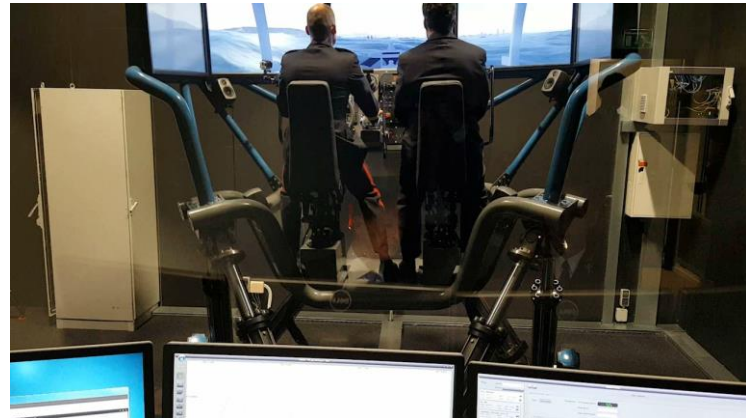
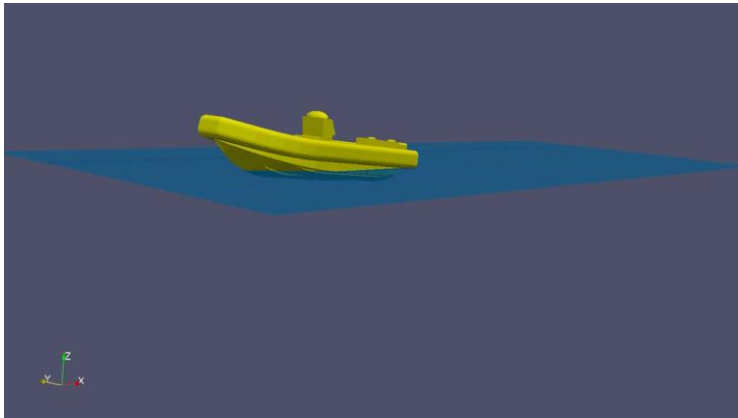

- Hull resistance
- Propeller characteristics
- Interactions ship ↔ environment (current, waves, wind, ...)
- Computational Fluid Dynamics (CFD – calculations)
- Constructional Fatigue
- Propulsion, Power & Energy systems
- ...

Lots of (simulation) models !



Reality

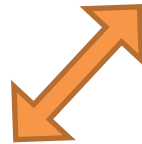

Model test
(scaled reality)



*Verification
&
Validation*

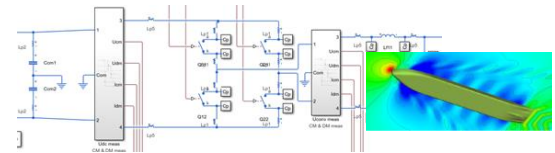

Simulation model
(digital)





Reality

- Design
- Verification
- Monitoring
- Diagnostics
- Prognostics

data

measured reality

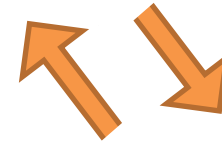

data

simulated reality

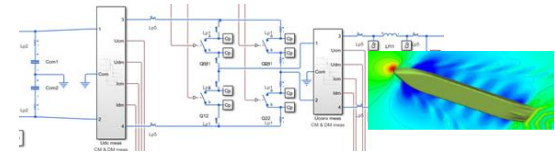

Simulation model
(digital)

A challenge in designing Propulsion, Power & Energy Systems:

What will be the best solution?

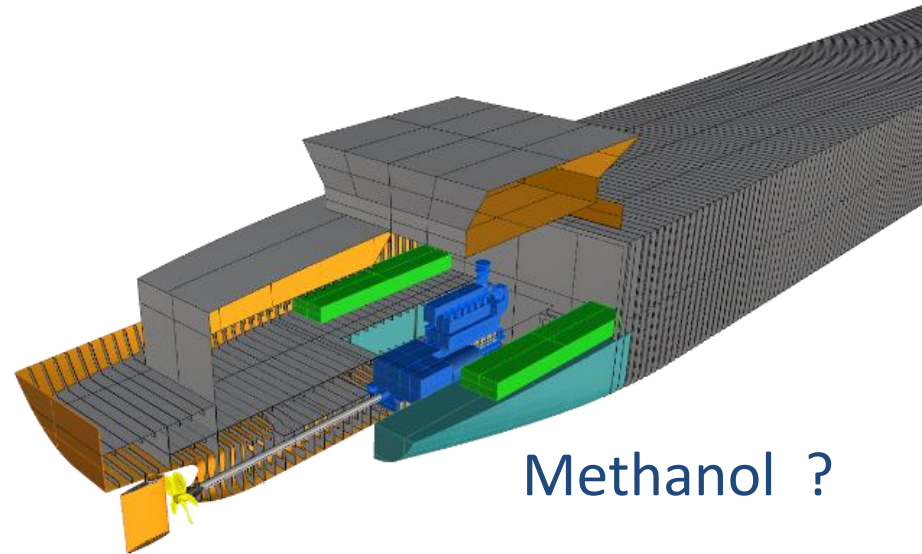

Methanol ?

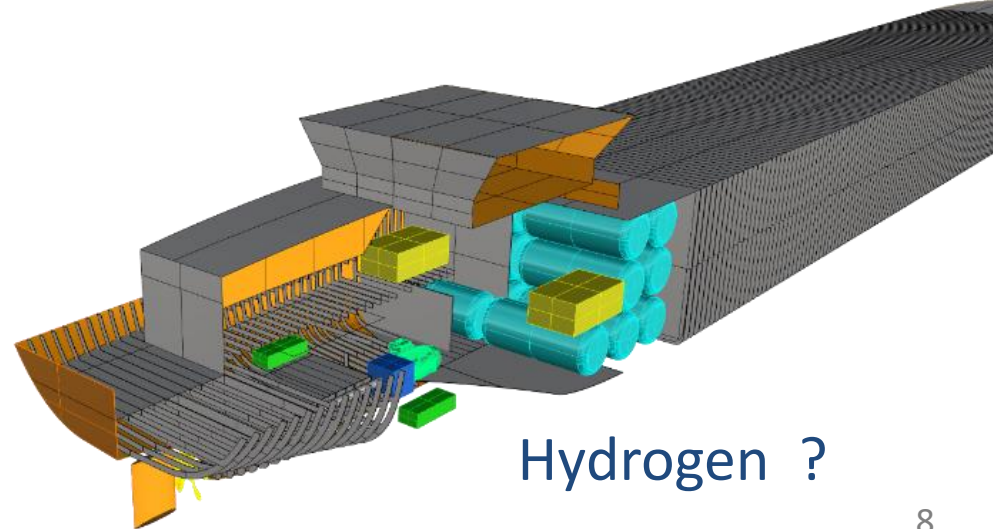

Hydrogen ?

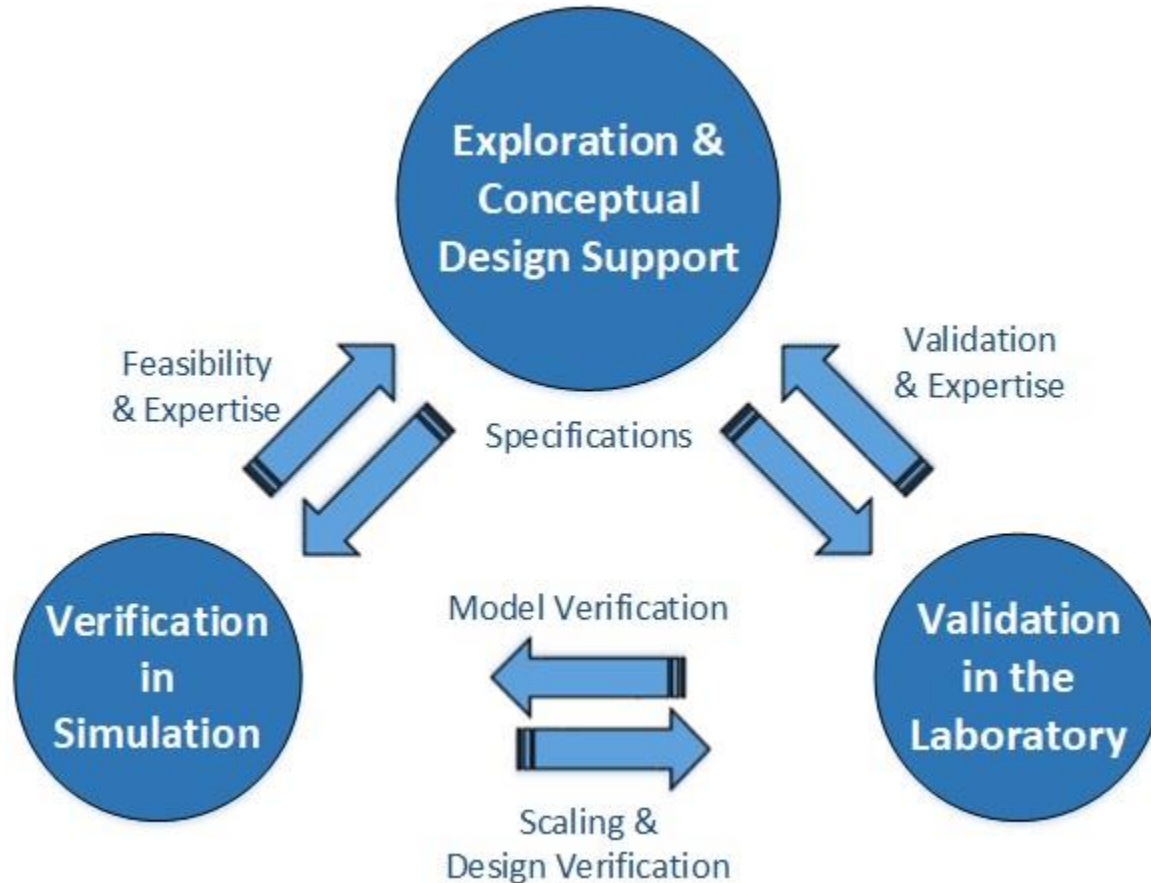

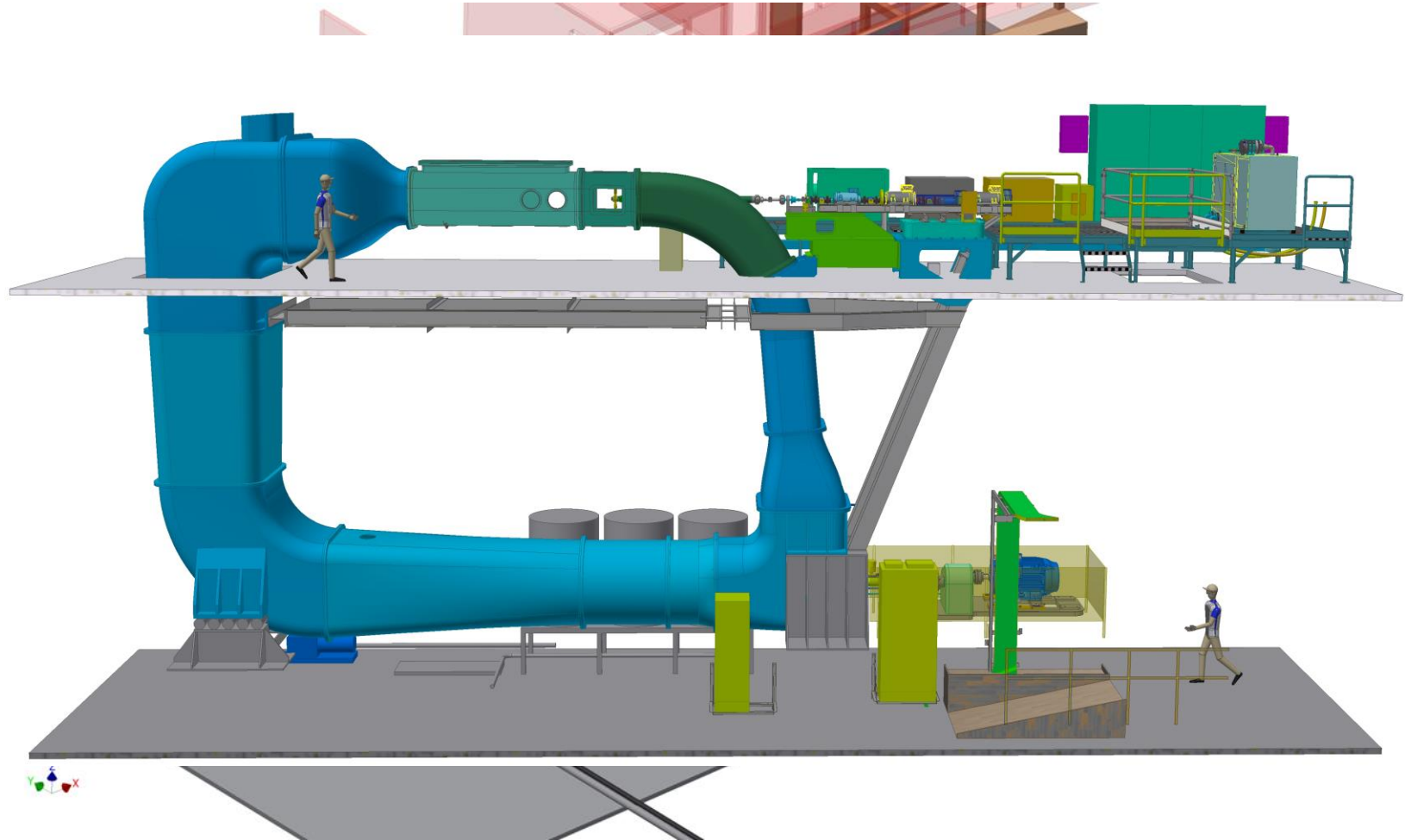

- Study & Test Propulsion, Power & Energy Concepts
- Components – Configuration
- Reliability
- Control Concepts
- ...

Versatile Facility for:

- Physical tests
- Virtual tests
- Hybrid tests

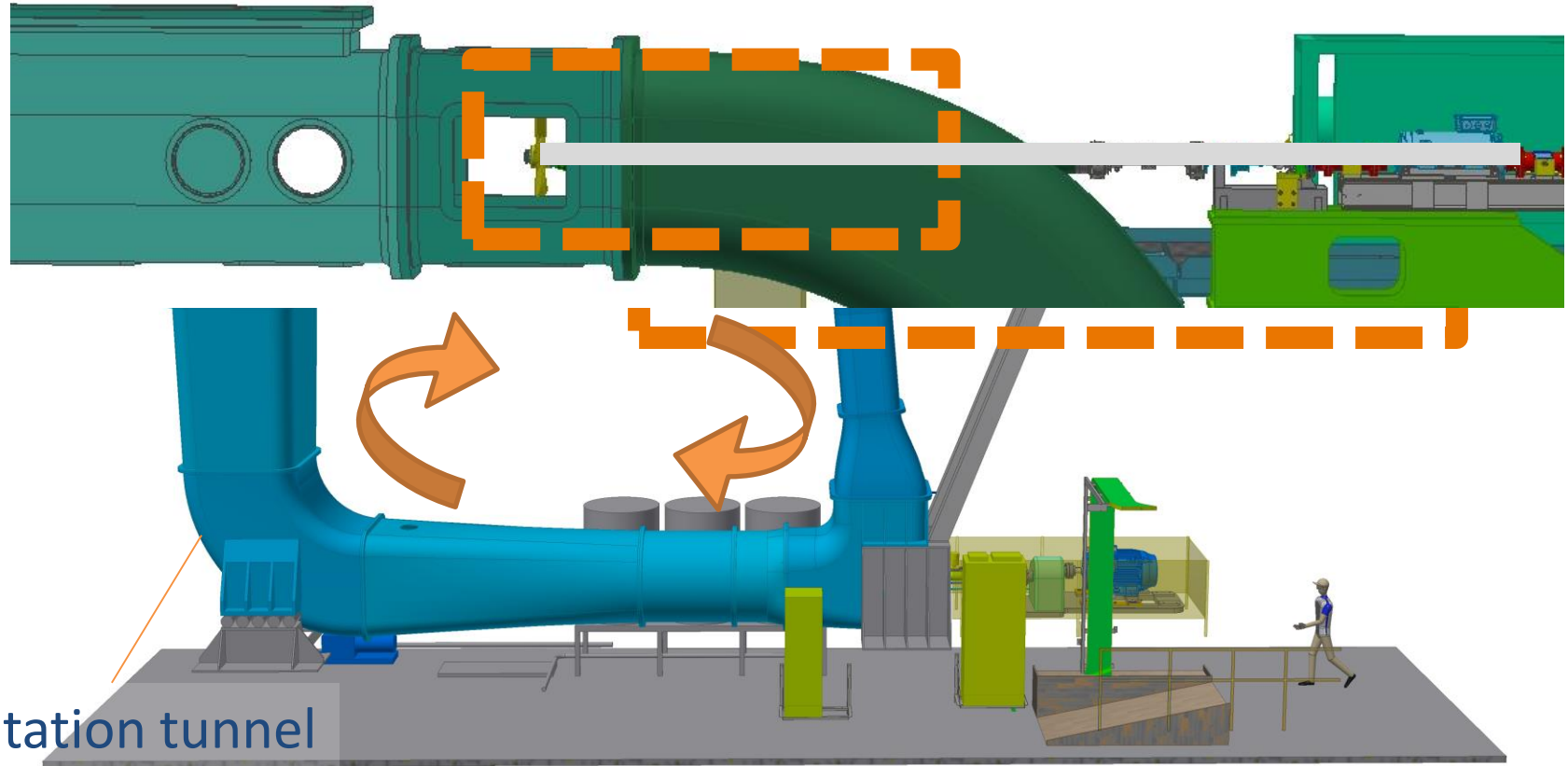

Cavitation tunnel

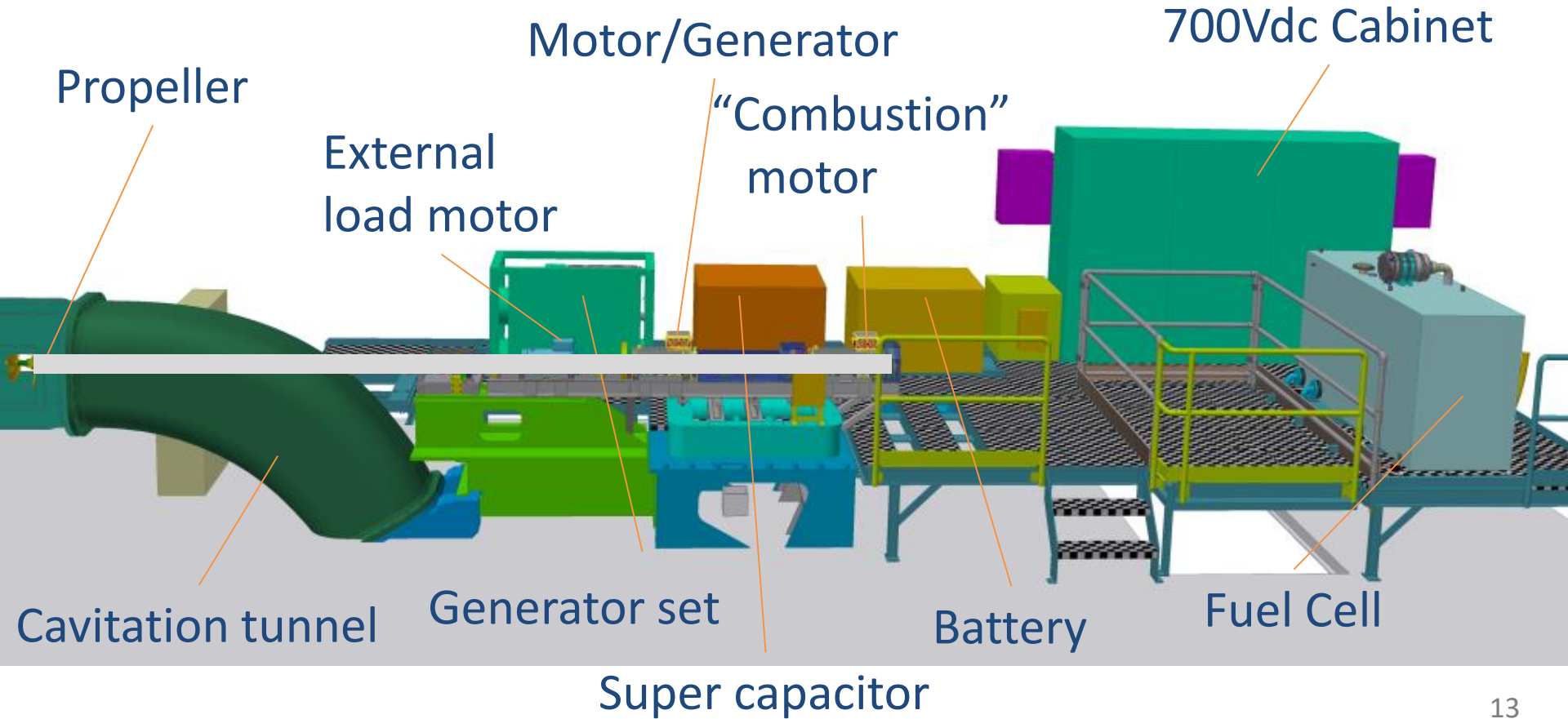



Electric Propulsion

Simulated External Disturbances

- Ship motion
- Waves
- Wind (assist)
- ...

Simulated Combustion Engines

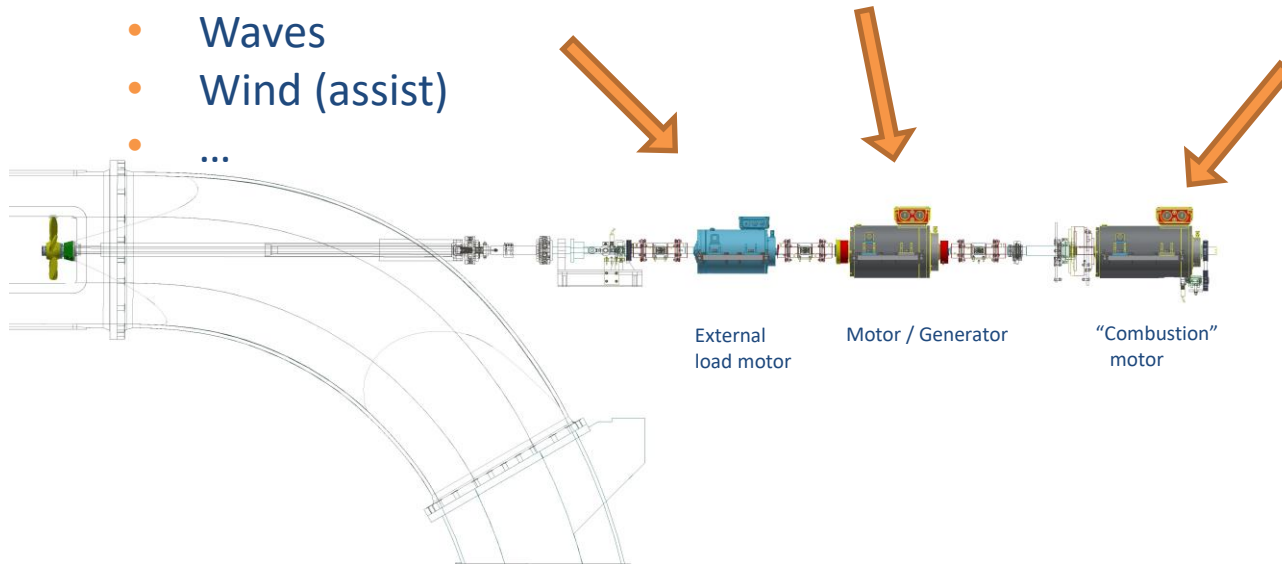

Example – Modelling an Internal Combustion Engine

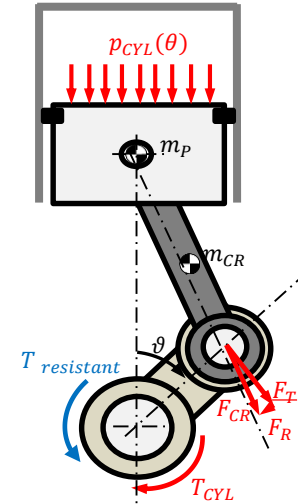
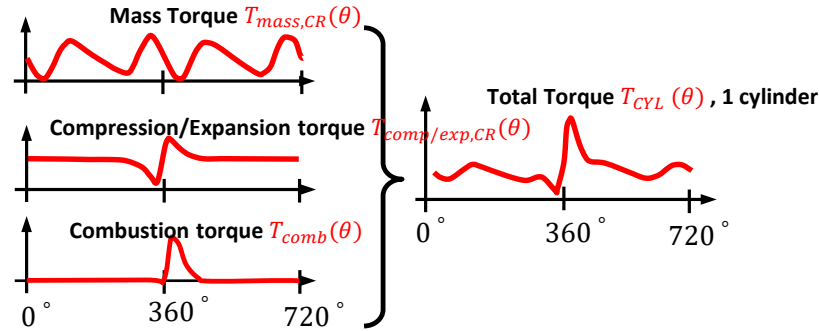
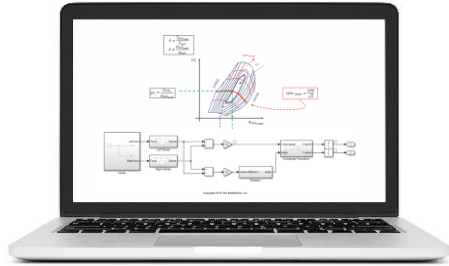

Configurable:

- Engine type
- Size
- Fuel type
- ...

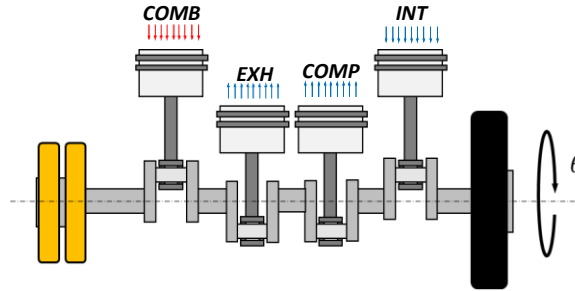

$$T_{CYL} = T_{comb} + T_{mass,CR} + T_{friction,CR}$$

$$T_{resistant} = T_{load} + T_{comp/exp} + T_{inertias} + T_{friction} + T_{elastic}$$

Example – Modelling an Internal Combustion Engine

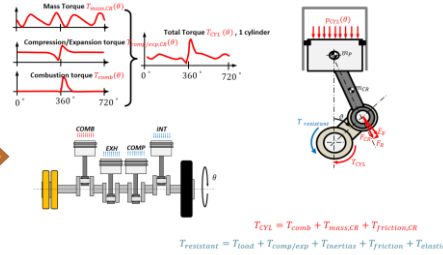
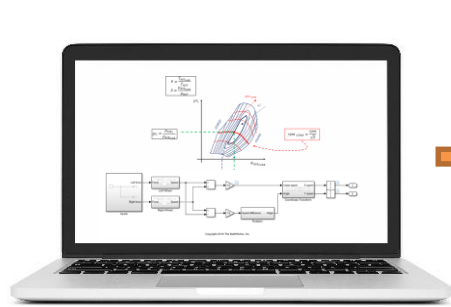

Example – Modelling an Internal Combustion Engine

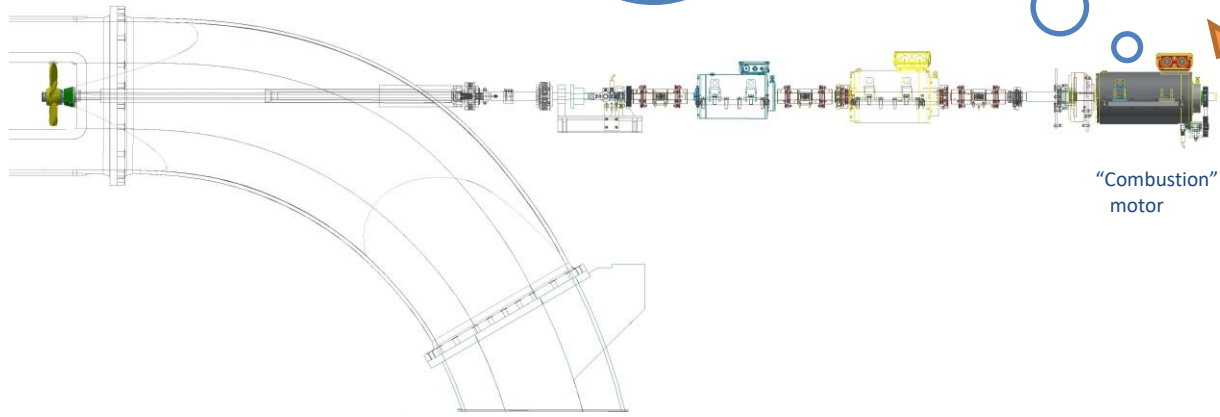
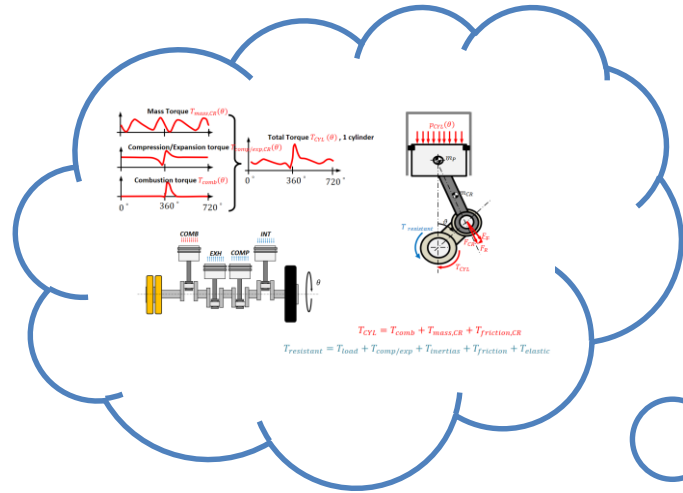

Example – Electric Drive

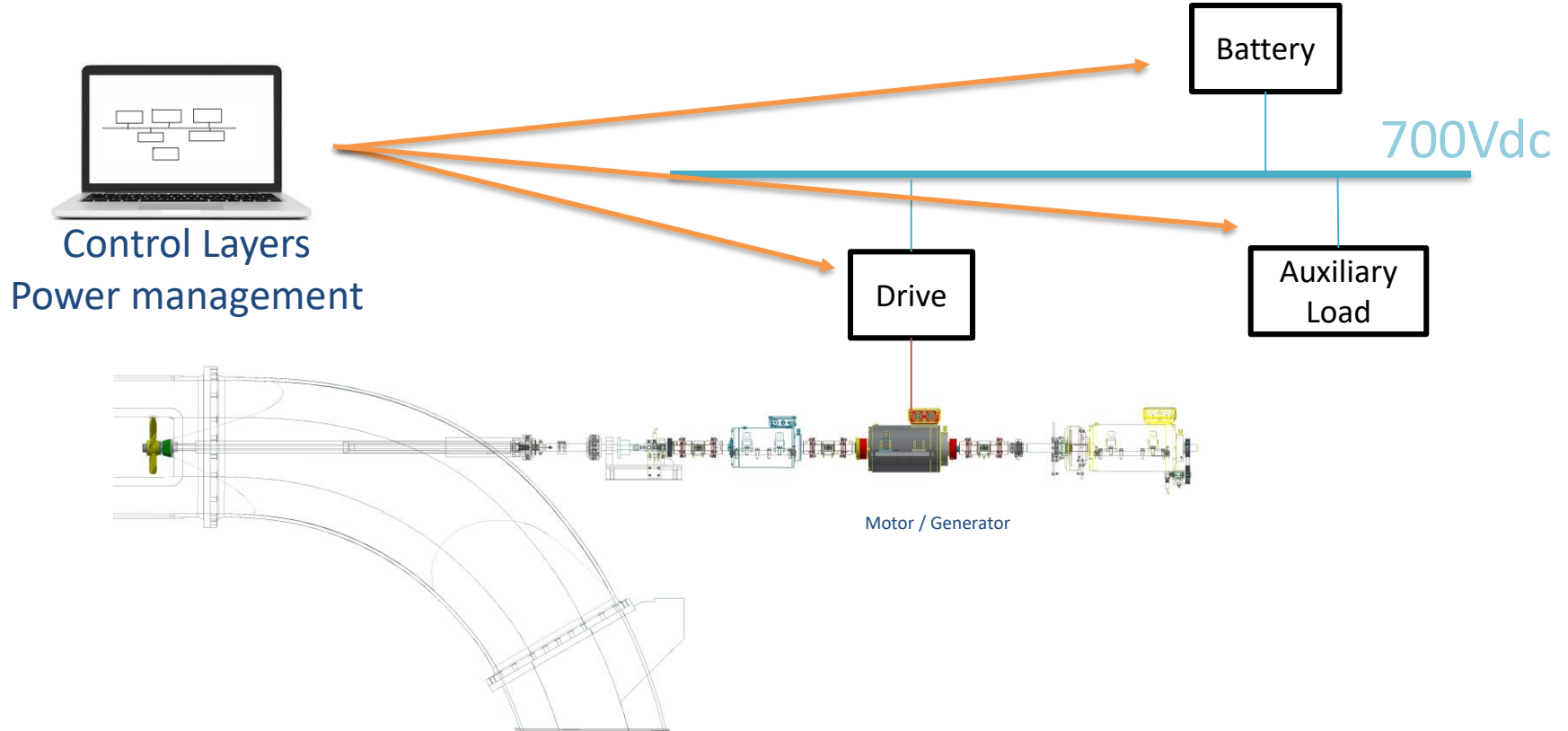

Example – Generic Convertor

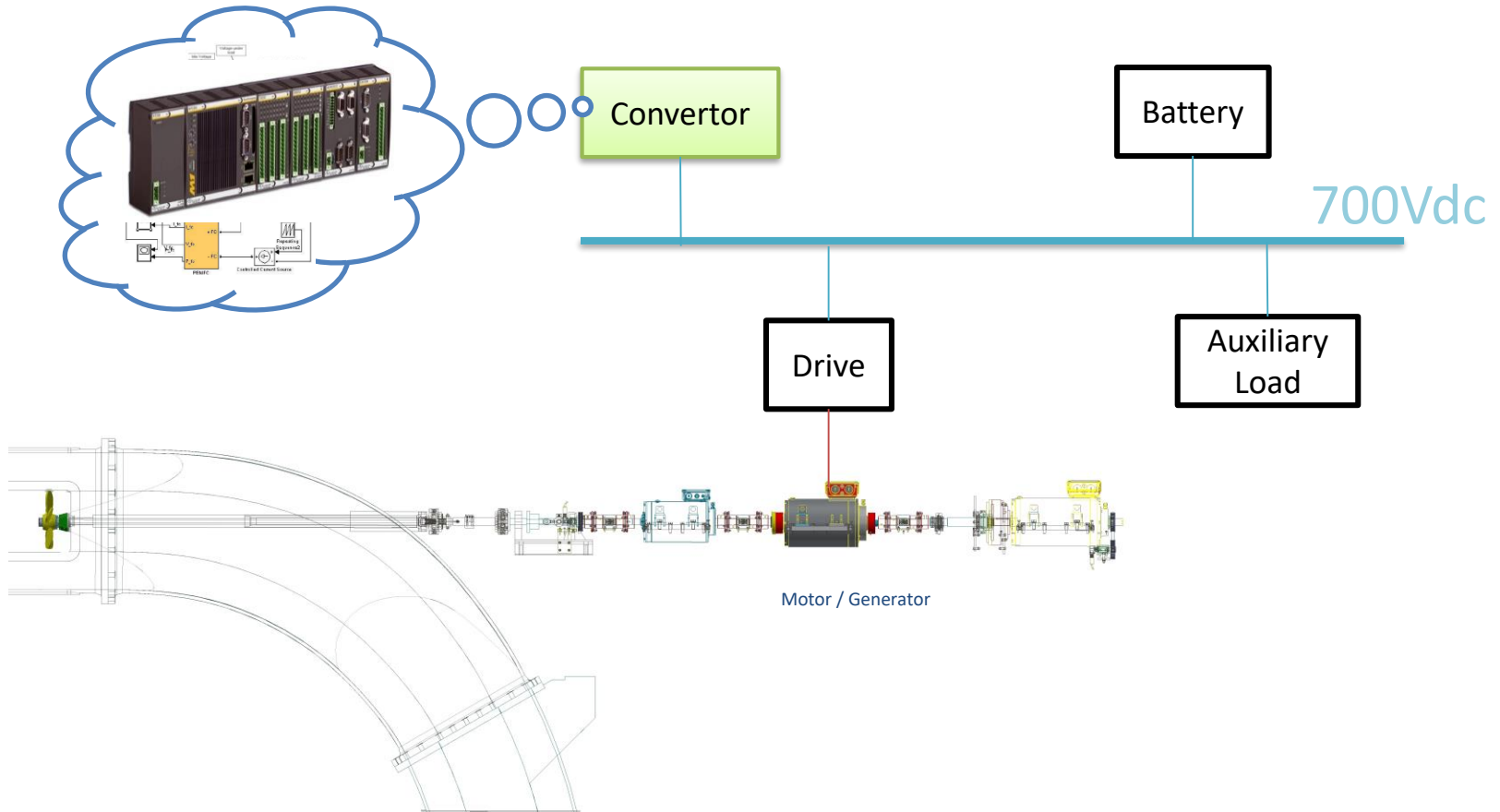



Simulated External Disturbances

- Ship motion
- Waves
- Wind (assist)
- ...

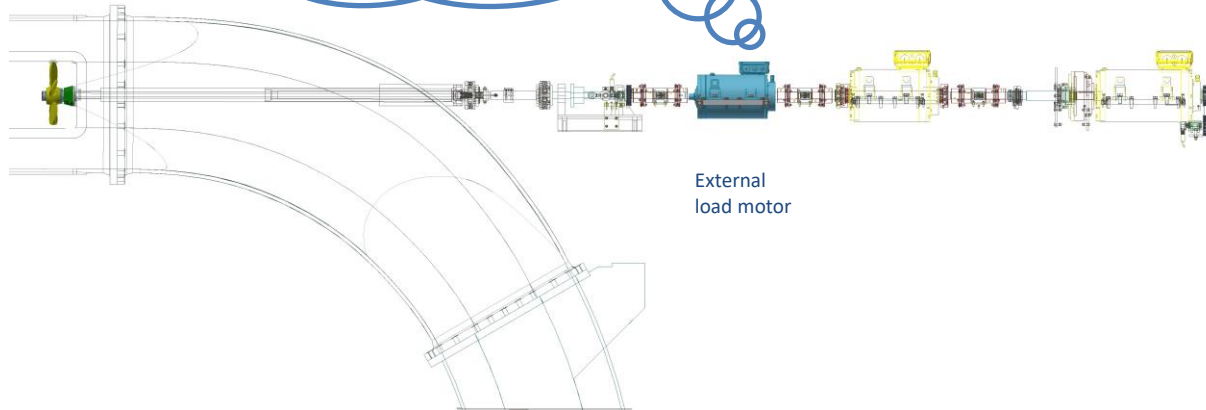

External
load motor

(Virtual) Zero Emissions Laboratory

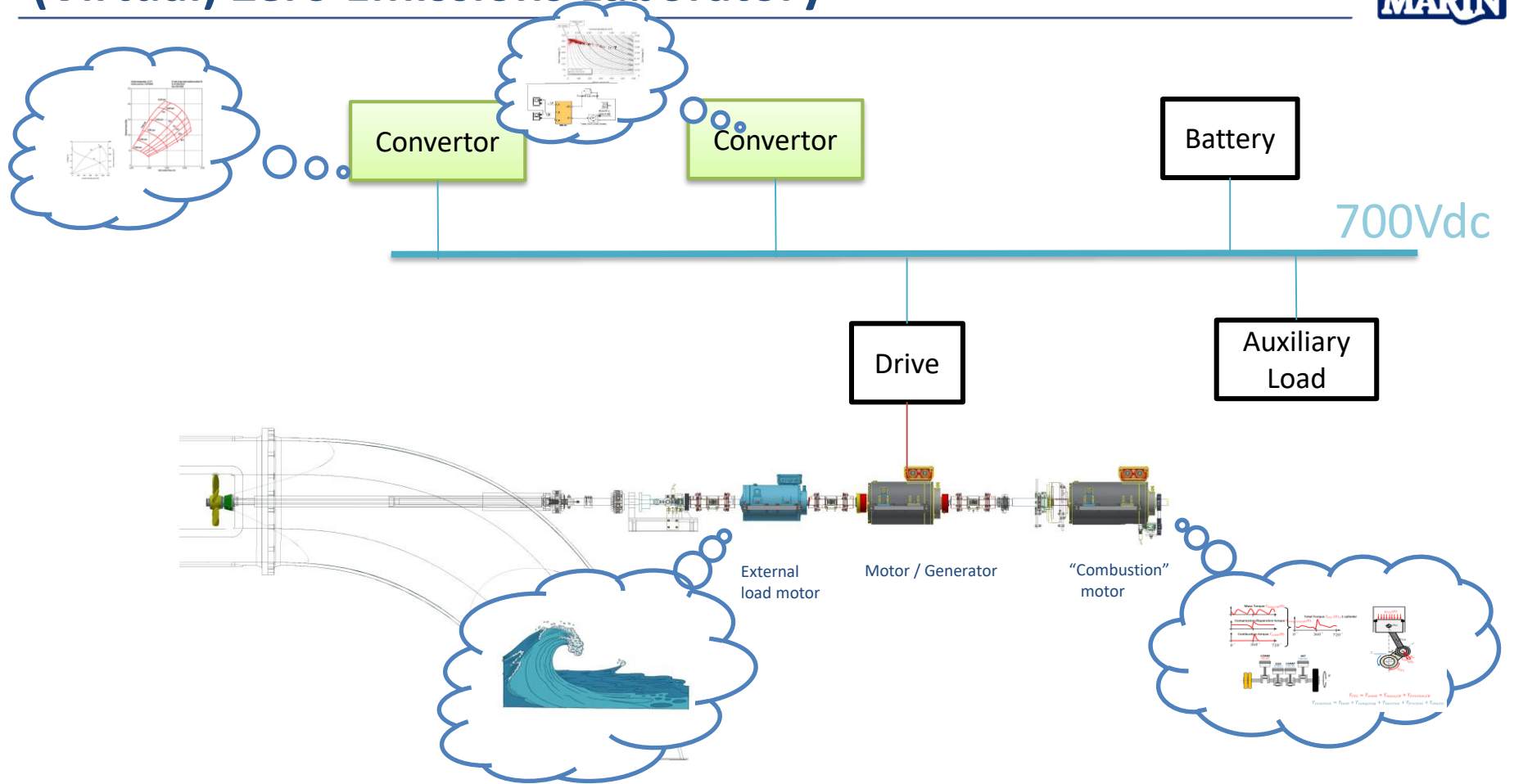

Stability Test 700Vdc grid

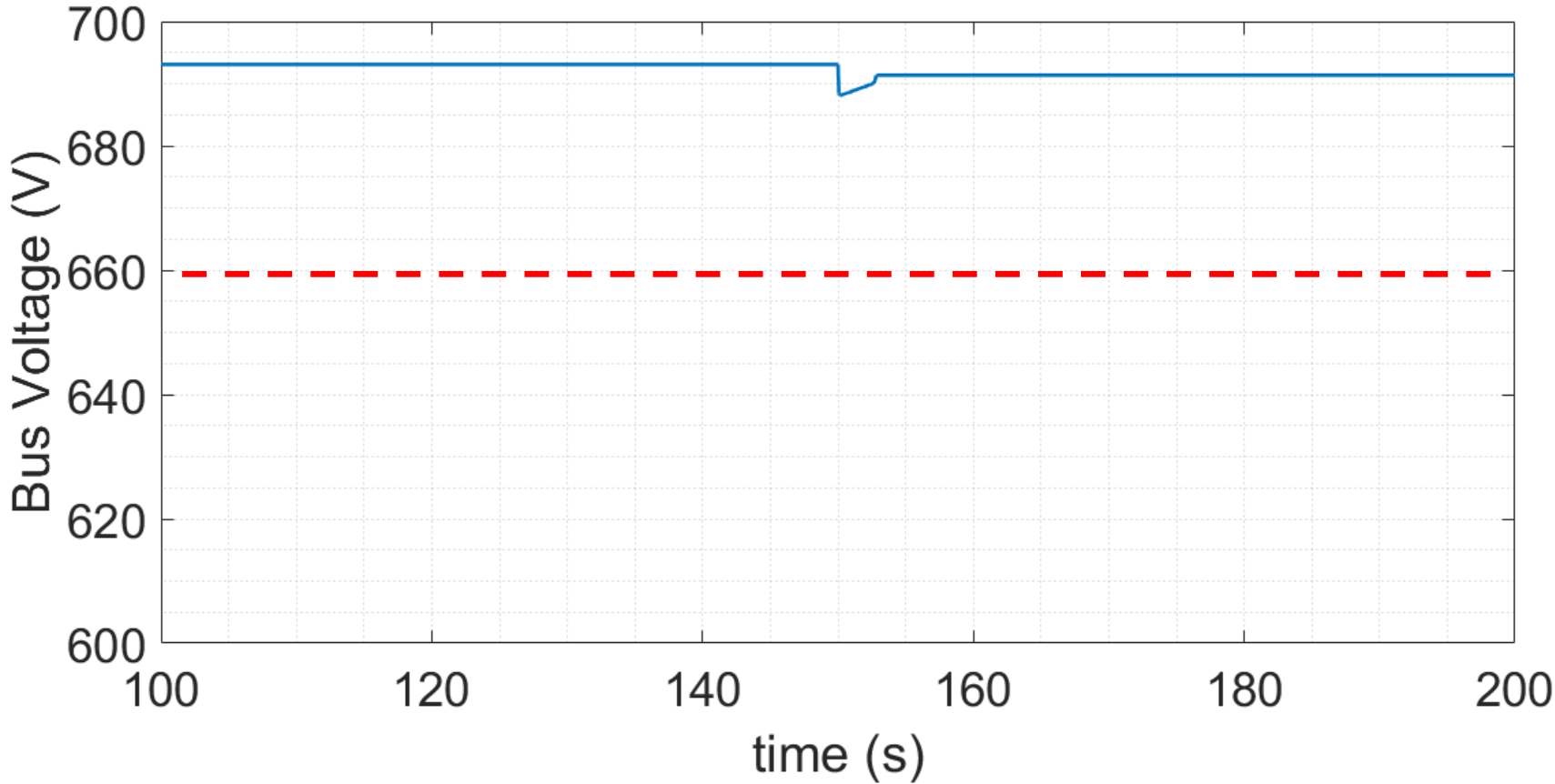

Current challenge in designing Propulsion, Power & Energy Systems:

What Power is really needed?

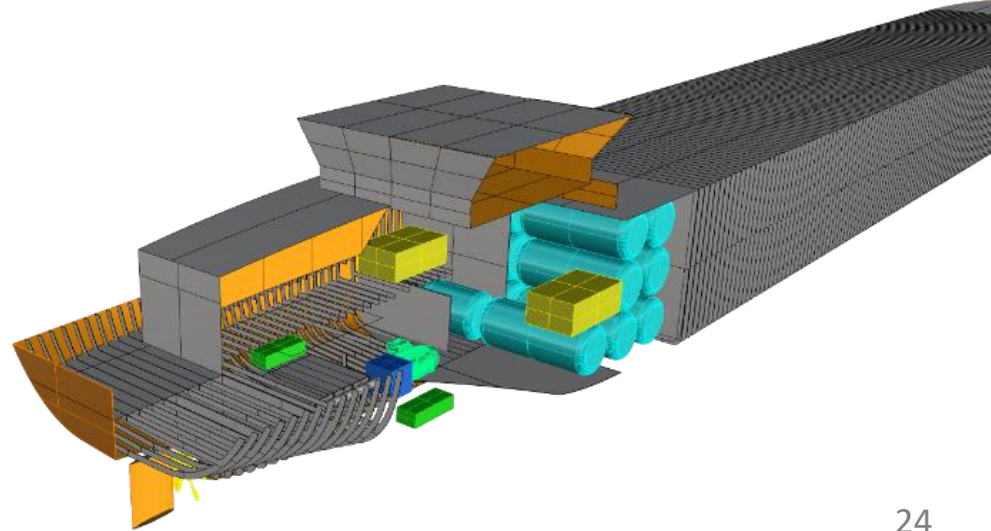
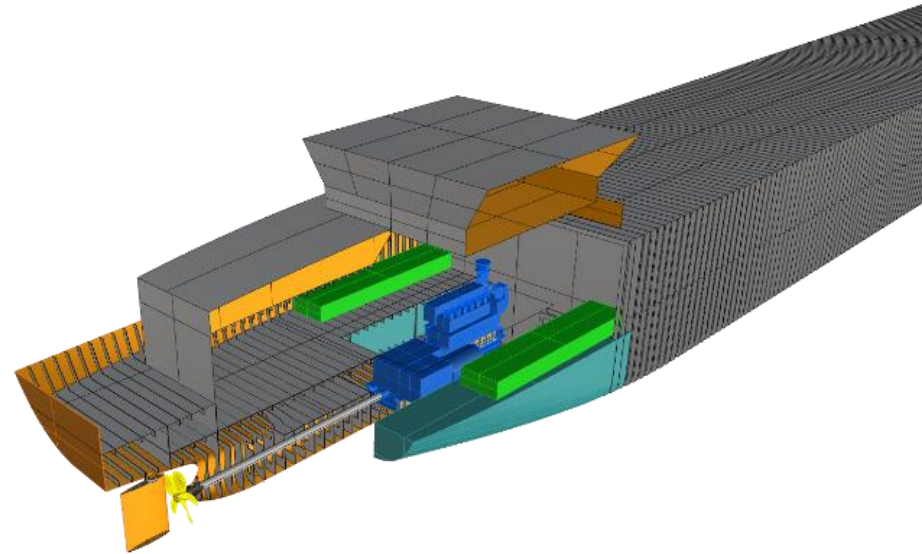

Typical Mission Power-Time chart [%max] - Inland Patrol Vessel Mission Surveillance

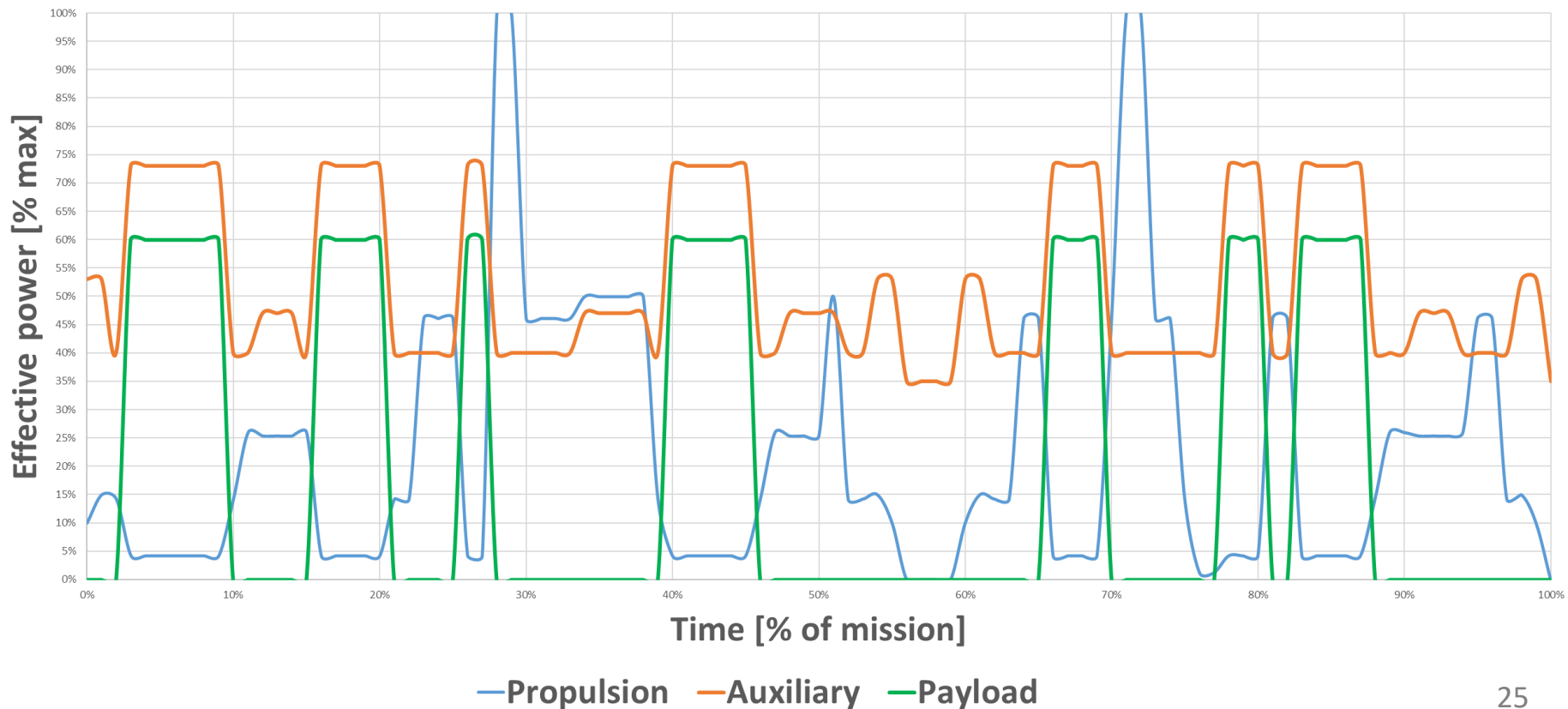

Power time charts

Measure



Measure

Measure

Measure Reality

Measure

Measure

Measure

Measure

Measure **data**

Measure

Measure

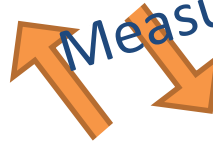

measured reality

data

Measure

simulated reality

Measure

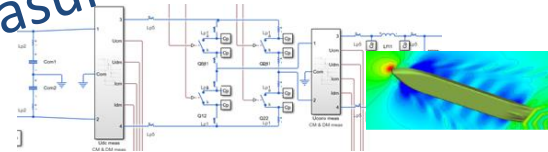

Simulation

(digital)

- 1:1 test upto 100 kW
- Scaled tests
- Various Simulated Power System Components

versus Actual ...

Digital meets (scaled) Reality

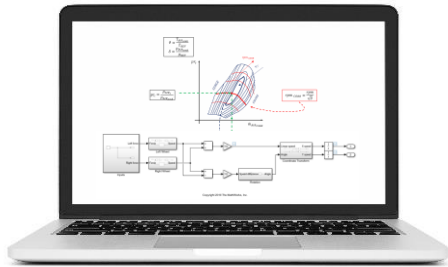

Virtual-ZEL



Zero Emission Lab



Machine room

Realiteit !

Digitale tweelingen, magische technologie of een illusie?

Thank you







[NL](#)
[ENG](#)